

**RATES, TERMS, AND CONDITIONS APPLICABLE TO
WHOLESALE WIRELINE BROADBAND INTERNET TRANSPORT SERVICE**

FURNISHED BY

Wolverton Telephone Company-Minnesota

110 4th St East, P.O. Box 270
Park River, ND 58270

ILEC Study Area Code 361512
FCC 499 Filer I.D. 801093

FOR SERVICES
AS PROVIDED FOR HEREIN.

EFFECTIVE JULY 1, 2026

TABLE OF CONTENTS

Section 1: General

- 1.1 Application of Rates, Terms and Conditions
- 1.2 Definitions

Section 2: Terms and Conditions

- 2.1 Undertaking of the Company
 - 2.1.A Scope
 - 2.1.B Limitations
- 2.2 Obligations of the Wholesale Customer
- 2.3 Liabilities of the Company
- 2.4 Application for Service
- 2.5 Executed Agreements
 - 2.5.A Agreement
 - 2.5.B Technical Standards Supplement (“TS Supplement”)
- 2.6 Charges and Payments for Service or Facilities
 - 2.6.A Deposits
 - 2.6.B Description of Payment and Billing Periods
 - 2.6.C Taxes and Other Charges
 - 2.6.D Payment and Late Payment Charge
 - 2.6.E Credit Allowance/Service Interruptions
 - 2.6.F Service Interruption Measurement
- 2.7 Termination or Denial of Service by the Company
- 2.8 Billing Disputes

Section 3: Description of Service

- 3.1 General
 - 3.1.A Ethernet Transport Service Connection
 - 3.1.B Designated End User Premises
- 3.2 Service Options
- 3.3 Service Provisioning
 - 3.3.A Responsibility of the Company
 - 3.3.B Responsibility of the Wholesale Customer
- 3.4 Rate Regulations
 - 3.4.A Rate Elements
 - 3.4.B Rate Application
 - 3.4.C Minimum Period
 - 3.4.D Moves
 - 3.4.E WBITS Term and Volume Plan Rates
 - 3.4.F Monthly Transfer Limitations

TABLE OF CONTENTS (Cont'd)

Section 4: Rates and Charges

- 4.1 Monthly Recurring and Nonrecurring Line Charges
 - 4.1.A Monthly Service Provided over Residential and Business Lines – Rates by Term
 - 4.1.B Service Provided over Residential and Business Lines – Volume Commitment Discounts
 - 4.1.C Term and Volume Commitment Monthly Minimum Charges

1. General

1.1 Application of Rates, Terms and Conditions

1.1.A Wolverton Telephone Company-Minnesota, Incumbent Local Exchange Carrier (“ILEC”), study area designation 362512 with FCC Form 499 Filer ID 801093, is hereinafter referred to alternatively as “Company.”

1.1.B The rates, terms and conditions contained within this document, hereinafter referred to as “Rates, Terms and Conditions,” are applicable to the provision by the Company of Wireline Broadband Internet Transport Service, hereinafter referred to alternatively as “Service” or “Wireline Broadband Internet Transport Service” or “WBITS”, as specified herein. Service is furnished hereunder on a wholesale basis to Wholesale Customers who are Internet Service Providers (“ISPs”). Service is furnished subject to the availability of facilities and subject to transmission, atmospheric and like conditions. By accepting Service from the Company, a Wholesale Customer accepts these Rates, Terms and Conditions as a binding agreement between the Wholesale Customer and the Company.

1.1.C Under the Rates, Terms and Conditions the Company offers the Services subject to the jurisdiction of the Federal Communications Commission (“FCC”) pursuant to Title II of the Communications Act of 1934, As Amended, (47 USC § 201-276) on a common-carriage permissively detariffed basis.

These Rates, Terms and Conditions effect compliance with the FCC’s 2005 *Wireline Broadband Order* in which the FCC allowed rate-of-return ILECs to offer WBITS as a telecommunications service on a permissively detariffed basis. The FCC allows providers of WBITS, in lieu of filing tariffs with the FCC, to include rates, terms, and conditions in generally available offerings posted on their websites. See *Appropriate Framework for Broadband Access to the Internet over Wireline Facilities*, CC Dockets 02-33, 95-20, 98-10, 01-337, WC Dockets 04-242, 05-271, 20 FCC Rcd 14853, 70 FR 60222, FCC-05-150 (Released September 23, 2005) (*Wireline Broadband Order*).

1.1.D The Company offers Services where technically feasible within its Incumbent Local Exchange Carrier (“ILEC”) Study Area in the state of Minnesota. For purposes of interstate services, including permissively detariffed services as is comprehended by the Services, the Company’s Study Area is identified as a geographic area with a discrete Study Area Code (“SAC”) 361512.

1.1.E The provision of Service by the Company as set forth in these Rates, Terms and Conditions does not constitute a joint undertaking with the Wholesale Customer for the furnishing of any service.

1.1.F From time to time, the Company may at its sole discretion modify the Rates, Terms and Conditions. Modification will be effective thirty (30) days after both posting of revised Rates, Terms and Conditions on the Company’s Internet web site and mailing by United States Postal Service a copy of the revised Rates, Terms and Conditions to all Wholesale Customers currently a party to an executed Agreement as described in Section 2.5 following.

1.2 Definitions

Certain terms used throughout these Rates, Terms and Conditions are defined as follows.

Application for Service

An “Application for Service” is a standard order form submitted by a Wholesale Customer which includes all pertinent billing, technical, and other descriptive information which will enable the Company to provide the Service as required.

Broadband

For purposes of these Rates, Terms and Conditions, “Broadband” means transmission of IP data at speeds of 1 Mbps or higher upstream and 1 Mbps or higher downstream.

Business

“Business” means any activity that occupies the time, attention, and labor of a person or persons for the purpose of a livelihood, profit, government, provision or administration of education, organized not-for profit activity including, but not limited to, professional services.

Business Customer

A “Business Customer” is an End User Subscriber with one or more locations in the Company’s Study Area who operates a Business from the location or locations with Local Exchange Switched Voice Service provided to the location or locations by the Company or for which the Company has facilities in place such that the Company is capable of providing Local Exchange Switched Voice Service to the location.

Business Line

A “Business Line” is a line extending the Company’s telecommunications network capable of transporting WBITS to the premises of a Business Customer on a Voice-Data basis.

Company

The term “Company” refers to Wolverton Telephone Company-Minnesota, Study Area designation 362512 and FCC 499 Filer ID 801093 operating in the state of Minnesota.

Customer Provided Equipment

Terminal equipment or facilities provided by persons other than the Company and connected to the Company’s Services and/or facilities.

Digital Subscriber Line (“DSL”) Access Service Connection Point

The term “Digital Subscriber Line (“DSL”) Access Service Connection Point” is a location designated by the Company that serves as an aggregation point for the collection of Company WBITS traffic from multiple Digital Subscriber Line Access Multiplexers (“DSLAMs”) or comparable packet-mode data modem equipment. Wholesale Customers establish connections to the Company’s WBITS network at the Company-designated DSL Access Service Connection Point.

Downstream

“Downstream” refers of the flow of IP data from an ISP to an End User Subscriber designated premises such as, but not limited to an End User Subscriber’s home or business over the Company’s WBITS network.

End User

The term “End User,” as used in these Rates, Terms and Conditions, refers to the individual or business legally occupying through ownership, lease, rental or other similar legal device a premises within the Company’s Study Area that has legal authority to order utilities, telecommunications, information services and other services for the premises. The End User is a current Local Exchange Switched Voice Service customer of the Company.

End User Subscriber

The term “End User Subscriber,” as used in these Rates, Terms and Conditions, refers to the Retail customer of the Wholesale Customer served through the Company’s network and to which the Wholesale Customer orders WBITS for connection to the Wholesale Customer’s ETS connection at the Company’s DSL Access Connection Point. An End User Subscriber may be either a Residential Customer or a Business Customer.

Ethernet

The term “Ethernet” denotes a high-speed networking technology utilizing a packet-based Ethernet protocol. Ethernet enables Broadband multimedia traffic (i.e., voice, data and video) to be carried over the same network. Ethernet Transport Service (“ETS”) for connection to the Company’s WBITS network DSL Access Service Connection Point at the Company-designated Serving Wire Center (“SWC”) must be ordered from the Company pursuant to the regulations and rates in the Company’s Interstate Access Services Tariff.

Gbps

“Gbps” is the widely recognized abbreviation for “gigabits per second”, indicating a data transfer speed of one billion bits per second. Gbps is also referred to as “Gig.”

Incumbent Local Exchange Carrier (“ILEC”)

Incumbent Local Exchange Carrier (“ILEC”) has the same meaning as Section 251(h) of the Communications Act, as Amended 47 U.S.C. § 251(h)(1).

(1) DEFINITION.--For purposes of this section, the term “incumbent local exchange carrier” means, with respect to an area, the local exchange carrier that--(A) on the date of enactment of the Telecommunications Act of 1996, provided telephone exchange service in such area; and (B)(i) on such date of enactment, was deemed to be a member of the exchange carrier association pursuant to section 69.601(b) of the Commission’s regulations (47 C.F.R. 69.601(b)); Or (ii) is a person or entity that, on or after such date of enactment, became a successor or assign of a member described in clause (i).

Internet

The Internet is “the international computer network of both Federal and non-Federal interoperable packet-switched data networks.” 47 USC §230(f)(1). The Internet is also described as “the combination of computer facilities and electromagnetic transmission media, and related equipment and software, comprising the interconnected worldwide network of computer networks that employ the Transmission Control Protocol/Internet Protocol or any successor protocol to transmit information.” 47 USC §231(e)(3).

Internet Protocol (“IP”)

The Internet Protocol (“IP”) is the industry-standard method or protocol by which data is sent from one computer to another on the Internet.

Internet Service Provider (“ISP”)

An Internet Service Provider (“ISP”) is an organization that provides access to the Internet. The ISP provides the username and password to the End User Subscriber.

JSI Tariff F.C.C. No. 1

JSI Tariff F.C.C. No. 1, or Interstate Access Services Tariff, is the interstate access tariff filed by John Staurulakis, Inc. (JSI) on behalf of issuing carriers. The Company is an issuing carrier for JSI Tariff F.C.C. No. 1. Because the Company is an issuing carrier, it is pursuant to the rates and regulations of JSI Tariff F.C.C. No. 1 that Wholesale Customers must order interstate Ethernet Transport Service (“ETS”) services required for connection to the Company’s network at the Company’s DSL Access Connection Point.

kbps

“kbps” is the widely recognized abbreviation for “kilobits per second”, a measure of data transfer speed. The “k” in kbps is lowercase to indicated measurement in decimal, i.e. 512 kbps is 512 kilobits per second.

KB

“KB” is the widely recognized abbreviation for kilobyte, equal to 1,000 bytes of data without respect to speed of transmission. Where a byte comprises eight bits, transmission of one KB at 1,000 kbps would take approximately eight seconds. Storage of data is generally measured in kilobytes and, in turn, the size of a file for transmission over the Internet is measured in kilobytes (data storage is also measured in KBs). For purposes of these Rates, Terms and Conditions, monthly data transmission limits are set at levels of KBs.

Local Exchange Switched Voice Service

“Local Exchange Switched Voice Service” is voice grade access to the public switched telephone network (“PSTN”) provided by the Company to the End User for a charge that enables the End User to transmit voice communications, including signaling the network that the caller wishes to place a call, and to receive voice communications, including receiving a signal indicating there is an incoming call.

Mbps

“Mbps” is the widely recognized abbreviation for “megabits per second”, indicating a data transfer speed of one million bits per second.

Rates, Terms and Conditions

“Rates, Terms and Conditions” refers to this document as a whole comprising the rates, terms and conditions applicable to the provision of Service to Wholesale Customers by the Company.

Residence

A “Residence” is a dwelling place with a unique street address, rural delivery or other address recognized by the United States Postal Service or United States Census Bureau, notwithstanding the End User Subscriber may receive mail at a post office box, that is inhabited by a person or persons with legal control of the dwelling place and who are authorized to order service for the address. For purposes of this definition, a street address includes, where applicable, an apartment number or other such number indicating a unit within a multiple dwelling unit.

Residential Customer

A Residential Customer is an End User Subscriber currently served at a Residence with Local Exchange Switched Voice Service provided by the Company or for which the Company has facilities in place such that the Company is capable of providing Local Exchange Switched Voice Service. Where a person or persons operates a Business from a Residence, the End User Subscriber will be considered a Business Customer.

Residential Line

A “Residential Line” is a line extending the Company’s telecommunications network capable of transporting Service to the premises of a Residential End User Subscriber on a Voice-Data basis.

Retail

“Retail” means the provision of ISP services directly to the End User Subscriber by a Wholesale Customer through the Service provided under these Rates, Terms and Conditions. The relationship of the Wholesale Customer and its End User Subscribers is a retail relationship. For purposes of ISP services, the End User Subscriber has a direct relationship with the Wholesale Customer and not the Company.

Service

“Service” means the offerings of the Company comprising Wireline Broadband Internet Transport Service (“WBITS”).

Serving Wire Center

The term “Serving Wire Center” or “SWC” denotes the wire center from which the customer-designated premises would normally obtain Local Exchange Switched Voice Service from the Company. In the context of Service provided by the Company, the SWC is the location of the DSL

Access Service Connection Point and the point to which the Wholesale Customer would order ETS to complete transport from the Wholesale Customer's network to the Company's network.

Study Area

A "Study Area" is a geographic segment of an ILEC's telephone operations and generally corresponds to an Incumbent Local Exchange Carrier's entire service territory within a state for which the National Exchange Carrier Association, Inc. ("NECA") has assigned a six-digit Study Area code ("SAC").

Telecommunications

"Telecommunications" is the transmission of voice communications or, subject to the transmission capabilities of the service, the transmission of data, facsimile, signaling, metering, or any other form of intelligence.

Upstream

"Upstream" refers to the flow of IP data from an End User Subscriber customer designated premises such as, but not limited to an End User Subscriber's Residence or Business to a Wholesale Customer's Access Service Connection Point over the Company's network.

Voice-Data Service

The term "Voice-Data" when used in the context of WBITS refers to provision of the Service over Company facilities that also carry Local Exchange Switched Voice Service, subscribed to by the End User from the Company to the End User premises.

Wholesale

The term "Wholesale" when used in the context of these Rates, Terms and Conditions refers to provision of Service to ISPs who, in turn, provide Internet service to End User Subscribers.

Wholesale Customer

A "Wholesale Customer" is any individual, partnership, association, trust, corporation, cooperative or governmental agency or other entity operating as an Internet Service Provider that utilizes the Service provided by the Company under these Rates, Terms and Conditions. A Wholesale Customer, as set forth herein, is responsible for the payment of charges and for compliance with all applicable terms of the Rates, Terms and Conditions.

Wireline Broadband Internet Transport Service ("WBITS")

"Wireline Broadband Internet Transport Service" or "WBITS" is a high-speed data access service that is made available to ISPs for connection to the Company's End Users over existing Company facilities for provision of Broadband services employing Internet Protocol.

2. Terms and Conditions

2.1 Undertaking of the Company

2.1.A Scope

The Company makes Services available to Internet Service Providers (“ISPs”). Services are described in Section 3 of these Rates, Terms and Conditions.

Connecting the Wholesale Customer’s ISP network to the Company’s network requires the Wholesale Customer to order Public Packet Data Network transport services sufficient to carry the Wholesale Customer’s data between its premises and the Company’s designated DSL Access Service Connection Point. Public Packet Data Network transport services within the Company’s serving area must be obtained from the Company under the Company’s Interstate Access Services Tariff and the Company bills customers the rates established thereunder for services ordered pursuant thereto.

For purposes of connection from the Wholesale Customer Designated Premises (“CDP”) to the Company’s DSL Access Service Connection Point, the Company provides the following services pursuant to the Company’s Interstate Access Services Tariff and subject to technical capability.

Public Packet Data Network:

Ethernet Transport Service (ETS)

2.1.B Limitations

- (1) The Services provided pursuant to these Rates, Terms and Conditions are offered subject to the availability of facilities and the other provisions of these Rates, Terms and Conditions.
- (2) The Company does not undertake to transmit communications or messages, but rather furnishes facilities, Service and equipment for such transmissions by the Wholesale Customer.
- (3) The Company retains the right to deny Service to any Wholesale Customer which fails to comply with the rules and regulations of these Rates, Terms and Conditions, or other applicable rules, regulations or laws.

2.2 Obligations of the Wholesale Customer

2.2.A All Wholesale Customers assume general responsibilities in connection with the provision and use of the Company’s Service. General responsibilities are described in this section. When facilities, equipment, and/or communication systems provided by others are connected to the Company’s facilities, the Wholesale Customer assumes the additional responsibilities as set forth in Section 2.2, herein.

2.2.B The Wholesale Customer is responsible for the payment of all charges for any and all Services or facilities provided by the Company to the Wholesale Customer.

- 2.2.C The Wholesale Customer shall indemnify and save harmless the Company from and against all loss, liability, damage and expense, including reasonable counsel fees, due to claims for libel, slander, or infringement of copyright or trademark in connection with any material transmitted by the Wholesale Customer using the Company's Services; and any other claim resulting from any act or omission of the Wholesale Customer to the use of the Company's facilities.
- 2.2.D The Wholesale Customer shall reimburse the Company for damages to the Company's facilities caused by any negligence or willful act or acts on the part of the Wholesale Customer.
- 2.2.E In the event a suit is brought by the Company, or an attorney is retained by the Company to collect any bill or enforce the terms of these Rates, Terms and Conditions against a Wholesale Customer, that Wholesale Customer shall be responsible for payment of all reasonable attorney's fees, court costs, costs of investigation and any and all other related costs and expenses incurred by the Company in connection therewith.
- 2.2.F The Wholesale Customer understands that the Services are furnished subject to the condition that there will be no abuse, fraudulent and/or illegal use thereof. Such activity includes, but is not limited to:
- (1) Using the Service for any purpose which is in violation of any law.
 - (2) Obtaining or attempting to obtain Services through any scheme, false representation and/or use of any fraudulent means or devices whatsoever with the intent to avoid payment, in whole or in part, of charges for Services, or assisting any other person or firm in such regard.
 - (3) Using the Services in a manner that interferes unreasonably with the use of Service by one or more other Wholesale Customers.

2.3 Liabilities of the Company

Except as stated in this Section 2.3, the Company shall have no liability for damages of any kind arising out of or related to events, acts, rights or privileges contemplated in the Rates, Terms and Conditions.

- 2.3.A The liability of the Company for damages resulting in whole or in part from or arising in connection with the furnishing of Service under the Rates, Terms and Conditions including, but not limited to, mistakes, omissions, interruptions, delays, errors or other defects or misrepresentations shall not exceed an amount equal to the charges under the Rates, Terms and Conditions applicable to the specific Service (or portion thereof) that was affected. No other liability shall attach to the Company.
- 2.3.B The Company shall not be liable for any failure of performance hereunder due to causes beyond its control, including, but not limited to: (1) acts of God, fires, flood or other catastrophes; (2) any law, order, regulation, directive, action or request of the United States Government, or any other government, including state and local governments having jurisdiction over the Company, or of any department, agency, bureau, corporation or other instrumentality of any one or more of said governments, or of any civil or military authority; or (3) national emergencies, insurrections, riots, wars or other labor difficulties.

2.3.C The Company shall not be liable for any act or omission of any other entity furnishing facilities, equipment, or services used by a Wholesale Customer, with the Company's Services. In addition, the Company shall not be liable for any damages or losses due to the failure or negligence of any Wholesale Customer or due to the failure of Wholesale Customer provided equipment, facilities or services.

2.4 Application for Service

The Wholesale Customer must place an Application for Service with the Company to initiate, cancel or change the Services provided pursuant to these Rates, Terms and Conditions. Applications for Services may be either in writing or orally and provide, at a minimum, the following information:

2.4.A Wholesale Customer's name(s), telephone number(s) and address(es). In the case of a corporation or partnership, a designated officer or agent shall be named as the contact person for such corporation or partnership.

2.4.B Name(s), address(es) and telephone number(s) of person(s) to whom notices from the Company to the Wholesale Customer shall be addressed, if different from (A) above.

Executed Agreements

2.5.A Agreement

The Company and the Wholesale Customer shall execute an agreement ("Agreement") setting forth, based on the Wholesale Customer's Application for Service, the specific Services available under the Rates, Terms and Conditions that the Wholesale Customer is ordering, the terms and volume commitments the Wholesale Customer is establishing, the type and volume of ETS the Wholesale Customer is ordering under the Company's Interstate Access Services Tariff. The Agreement shall incorporate by reference these Rates, Terms and Conditions. The Rates, Terms and Conditions incorporated by reference into the Agreement should be the current Rates, Terms and Conditions posted on the Company's web site or delivered to the Wholesale Customer by United States Postal Service, subject to amendment by the Company from time to time as provided for in Section 1.1.F.

2.5.B Technical Standards Supplement ("TS Supplement")

The Company and the Wholesale Customer shall agree to the industry technical standards applicable to the transmission of data between the Wholesale Customer and the Company through use of the Company's Service provided pursuant to these Rates, Terms and Conditions and the Agreement. The agreed to technical standards shall be documented in the Technical Standards Supplement ("TS Supplement"). The TS Supplement shall be signed by both the Company and the Wholesale Customer and incorporated by reference into the Agreement.

The TS Supplement can be amended, from time to time, based on mutual agreement of the Wholesale Customer and the Company. If an industry standard becomes obsolete or is otherwise no longer supported by vendors associated with the Company's network, any duties with respect to technical standards are vitiated. In the event the Wholesale Customer and the Company do not come to agreement regarding replacement industry standards, the Company shall choose the replacement industry standard most commonly used by the industry.

2.6 Charges and Payments for Service or Facilities

2.6.A Deposits

- (1) The Company may, in order to safeguard its interests, require a Wholesale Customer to make a suitable deposit or provide a surety bond or letter of credit in the amount of the required deposit as a guarantee of the payment of charges. The Company shall have the right to require the Wholesale Customer to make a deposit prior to or at any time after provision of any Service, not to exceed three (3) months estimated charges. The Company may increase the amount of the deposit to reflect increases to the Wholesale Customer's annual bill. The Wholesale Customer will receive a receipt for the deposit.
- (2) Any deposit as referred to in this Section shall be held by the Company to secure the payment of the Wholesale Customer's bill. At the Company's option, the deposit may be refunded or credited to the Wholesale Customer at any time prior to the termination of Service.
- (3) Interest will be paid by the Company on all sums held on deposit at the rate established statutorily for customer deposits. The interest will be accrued for the period during which the deposit is held by the Company.
- (4) The fact that a deposit is made does not relieve the Wholesale Customer from making advance payments or from complying with the Company's regulations for the payment of bills in accordance with the terms herein and does not constitute a waiver or modification of the regulations of the Company providing for the discontinuance of Service for nonpayment of any sums due the Company for Service rendered.
- (5) Upon termination of Service, and assuming deposits of the Wholesale Customer are not applied as indicated in Section 2.6.A.2, the deposit will be credited to the Wholesale Customer's account and any credit balance will be refunded after all amounts due the Company have been paid.

2.6.B Description of Payment and Billing Periods

- (1) Service is provided and billed in advance on a monthly basis. Service continues to be provided and billed on a monthly basis until canceled by the Wholesale Customer through written notice given to the Company. Cancellation for individual Service lines will take effect within five business days following receipt by Company of Wholesale Customer's written notice of cancellation.
- (2) The Company shall establish the start date for monthly bill periods and such monthly periods shall continue through the term of the Agreement.
- (3) Proration of Charges

The Company does not pro-rate for the quantities of Services in the billing period, instead a snapshot of active accounts is used for billing. The Company shall bill the Wholesale Customer

based on the number of WBIAS lines in service as of the bill rendering date for each active account in use.

2.6.C Taxes and Other Charges

In addition to payment for Services, Wholesale Customer must pay all taxes, fees, surcharges and other charges that the Company bills Wholesale Customer related to Services. Taxes and surcharges will be in the amounts that federal, state and local authorities require the Company to bill Wholesale Customers. The Company will not provide advance notice of changes to taxes and surcharges, except as required by applicable law. All such taxes and charges shall be separately shown and charged on bills rendered by Company or its billing agent.

2.6.D Payment and Late Payment Charge

- (1) Payment will be due as specified on the Wholesale Customer bill. Commencing after that due date, a late charge of up to the highest interest rate allowable by state laws will be applied to all amounts past due.
- (2) Collection procedures and the requirement for a deposit are unaffected by the application of a late payment charge. The late payment charge does not apply to unpaid balances associated with disputed amounts. Undisputed amounts on the same bill are subject to the late payment charge if unpaid and carried forward to the next bill.
- (3) Service may be denied or discontinued at the Company's discretion for nonpayment of amounts due the Company past the due date as specified in 2.6.D(1). Restoration of Service will be subject to all applicable installation charges.

2.6.E Credit Allowance/Service Interruptions

- (1) Credit for failure of Service will be allowed only when failure is caused by or occurs in the Company's facilities or equipment owned, provided and billed for by the Company. A credit allowance is not applicable for any period during which Wholesale Customer cannot utilize the Service, except for such period where the Service is interrupted by the Company for access to its facilities for the purposes of investigating and clearing troubles and/or maintenance.
- (2) Credit allowances for failure of Service or equipment starts when the Wholesale Customer notifies the Company of the failure and ceases when the operation has been restored and an attempt has been made to notify the Wholesale Customer by the Company.
- (3) The Wholesale Customer shall notify the Company of failures of Service or equipment and make reasonable attempts to ascertain that the failure is not caused by Customer Provided Equipment or Customer provided facilities, any act, or omission of the Wholesale Customer, or in wiring or equipment connected to the Wholesale Customer's terminal.
- (4) Only those portions of the Service or equipment operation disabled will be credited.

2.6.F Service Interruption Measurement

- (1) In the event of an interruption of Service that exceeds the minimum requirements set forth in this paragraph, the Company shall make a credit allowance at the Wholesale Customer's request for a pro rata adjustment of all Service charges billed by the Company for Services rendered inoperative by the interruption. The credit allowance will be computed by dividing the duration of the Service interruption measured in twenty-four (24) hour days, from the time the interruption is reported to the Company, by a standard thirty (30) day month, and then multiplying the result by the Company's fixed monthly charges for each interrupted Service.
- (2) A credit allowance will not be given for interruptions caused by the negligence or willful act of the Wholesale Customer, or interruptions caused by failure of equipment or service not provided by the Company.

2.7 Termination or Denial of Service by the Company

2.7.A The Company may, immediately and without notice to the Wholesale Customer, and without liability of any nature, temporarily deny, terminate, or suspend Service to any Wholesale Customer:

- (1) In the event such Wholesale Customer or its agent: (a) willfully damages the Company equipment, interferes with use of the Company's Service by other Wholesale Customers of the Company; (b) unreasonably places capacity demands upon the Company's facilities or Service; or (c) violates any statute or provision of law, or any rule or regulation of any state or federal regulatory agency relating to communications; or (d) otherwise fails to comply with the provisions of these Rates, Terms and Conditions or applicable law; or
- (2) In the event a Wholesale Customer becomes insolvent, is the subject of any formal legal proceeding commenced in a court involving a voluntary or involuntary petition or proceeding in bankruptcy, seeks protection or relief from creditors in a formal legal proceeding after a filing for such relief, or executes an assignment for the benefit of creditors; or
- (3) In the event that the Company determines that any Service is being used fraudulently or illegally, whether by a Wholesale Customer or its agent.

2.8 Billing Disputes

If Wholesale Customer believes Wholesale Customer has been billed by the Company in error, Wholesale Customer must contact the Company within thirty (30) days of the date of the bill which contains the disputed charge. Refunds or adjustments will not be issued for any charge that is more than thirty (30) days old at the time Wholesale Customer notifies the Company. Wholesale Customer may withhold from payment to the Company the disputed portion of any bill pending resolution of the dispute. Wholesale Customer must pay all non-disputed charges on the bill by the due date indicated on the bill. The Company will notify Wholesale Customer of the results of its inquiry, and either adjust the billing, issue a credit, or notify Wholesale Customer that all or a portion of the disputed amount is still owed. Wholesale Customer will be required to pay such amount within fifteen, (15) days thereafter, and if Wholesale Customer fails to pay this amount within the time required, Wholesale Customer's account will be deemed past due and unpaid and Wholesale Customer's Service subject to termination under Section 2.6 above. Any payments Wholesale

Customer withholds pending resolution of the dispute may be subject to a late payment charge at the highest interest rate allowable by law applied to past due amounts.

3. Description of Service

3.1 General

Wireline Broadband Internet Transport Service (“WBITS”) enables data traffic generated by a Wholesale Customer provided modem to be transported from the premises of the Company’s End User to the Company’s DSL Access Service Connection Point using the Company’s facilities. A DSL Access Service Connection Point is an interconnection point designated by the Company at which the Wholesale Customer may interconnect Service provided by the Company under the Agreement and Rates, Terms and Conditions with transmission facilities ordered by the Wholesale Customer under the Company’s ETS offerings under the Company’s Interstate Access Services Tariff. The DSL Access Service Connection Point aggregates Broadband data.

3.1.A ETS Connection

The Company offers transport of Network Service Provider traffic between the Network Service Provider’s designated premises and the DSL Access Service Connection Point through Ethernet Transport Service (ETS) provided under the Company’s Interstate Access Services Tariff.

3.1.B Designated End User Premises

The Company’s Service allows Wholesale Customers to establish Broadband Internet connections to the designated End User Subscriber premises. The designated End User Subscriber premises location must be served by an existing Company provided facility. A facility is the Serving Wire Center central office line equipment and all of the plant facilities up to and including the Company provided Network Interface Device (“NID”).

The connection speed or “sync rate” is between the NID at the End User Subscriber’s premises and the DSLAM. Actual data transfer or throughput may be lower than the sync-rate due to Internet congestion, server or router speeds, protocol overheads, End User Subscriber use of multiple applications and other factors that may not be under the Company’s control.

Service will be provided by the Company subject to the availability and limitations of Company Serving Wire Centers and outside plant facilities.

3.2 Service Options

Service is available in the downstream and upstream options established by the Company as indicated in each option offered by the Company shall specify the downstream and upstream speeds.

3.3 Service Provisioning

3.3.A Responsibility of the Company

- (1) Service will be provisioned over existing Company local exchange service lines.
- (2) Where fiber is installed to the End User Subscriber customer premises, subject to technical capability, the Company will provision Service over fiber facilities.
- (3) Where fiber facilities are not available, the Company will determine if the copper facilities are suitable for use with the Service option ordered by the Wholesale Customer. Service will not be provided on lines that are not suitable for Wireline Broadband Internet Transport Service or on lines that produce interference with other services provided by the Company.
- (4) The Company will provision and maintain Service for the Wholesale Customer between the NID at the End User Subscriber premises and the Wholesale Customer's Ethernet Transport Service DSL Access Service Connection Point.
- (5) The Company reserves the right to temporarily interrupt Service for wire center or network maintenance, software updates, and in emergency situations.

3.3.B Responsibility of the Wholesale Customer

- (1) The Wholesale Customer is responsible for obtaining and installing compatible End User Subscriber customer premises equipment (CPE, DSL modems and/or routers) used for connection to Company Service at the Service termination at the End User Subscriber location.
- (2) The Wholesale Customer is responsible for ensuring the continuing compatibility of CPE at the End User Subscriber premises. The Wholesale Customer and/or End User Subscriber shall be responsible for any expenses incurred for required changes to Wholesale Customer and/or End User Subscriber equipment or facilities in order to make such equipment or facilities compatible with the Company's Service.
- (3) The Wholesale Customer is responsible for providing the Company with the necessary information to provision the Service to its End User Subscribers.
- (4) The Wholesale Customer ordering service for connection to its End User Subscriber(s) must obtain and maintain record of a letter of agency authorizing the Wholesale Customer to act as the agent of the End User Subscriber. Upon request from the Company, Wholesale Customer will provide the Company with a copy of the letter of agency.
- (5) The Wholesale Customer must have connectivity to Company's Ethernet Transport Service network where Wholesale Customer chooses to purchase Service. The rates and charges for Ethernet Transport Service are in addition to the rates and charges for Service as set forth in these Rates, Terms and Conditions.

- (6) The Wholesale Customer will obtain the appropriate authorization from its End User Subscriber to allow the Company's employees or agents to enter the End User Subscriber's designated premises at any reasonable hour for the purpose of installing, inspecting, repairing or removing the NID or drop associated with Service.
- (7) The Wholesale Customer is responsible for providing all customer support, marketing, billing, ordering and repair to and for its Retail End User Subscribers.
- (8) The Wholesale Customer purchases Service under these Rates, Terms and Conditions on a Wholesale basis and is responsible for all dealings with End User Subscribers for Internet service provided by the Wholesale Customer on a retail basis.
- (9) The Wholesale Customer shall at all times be the customer of record with respect to all Services purchased hereunder and shall be responsible for payment to Company. Wholesale Customer retains all responsibility for billing its Retail End Users Subscribers and for any claim an End User Subscriber may make concerning unauthorized billing of Internet or related charges.

3.4 Rate Regulations

3.4.A Rate Elements

There are two types of rates and charges applicable to Service. These comprise a monthly Service line rate and nonrecurring charges associated with Service line ordered.

(1) Monthly Line Rates

The Monthly Line Rate applies each month for each line equipped with Service.

For purposes of application of the monthly rate, Service may be ordered under any of the following options that are offered by the Company as indicated following.

Monthly Rates Without Discount Wholesale Customers may order Service at a monthly rate without discount. Monthly rates apply without any volume commitment.

Term and Volume Plan (TVP) Rates Wholesale Customers may order Service under Term and Volume Plan (TVP) Rates as indicated following.

Service Classes Service is only provided as a Voice-Data class of service.

Service provided on the basis of voice-data is designed to support affordable Broadband Internet access for Residential and Business End User Subscribers. The actual throughput achieved by voice-data is not guaranteed and may be affected by many factors, such as Internet congestion. Service is provisioned over the End User Subscriber's existing Company Local Exchange Switched Voice Service line. When provisioned over the End User Subscriber's existing Local Exchange Switched Voice Service line, Service utilizes a centrally placed

splitter or in-line filters to isolate the voice band service and equipment from the Service and equipment.

Line Types Wholesale Service is provided to two types of Company lines: Residential Lines and Business Lines. Residential Lines and Business Lines are defined in Section 2.1, Definitions, preceding.

(2) Nonrecurring Charges

A nonrecurring charge applies per line for the installation of Service.

For three-year term and volume commitments of at least 300, nonrecurring charges do not apply to Service lines.

3.4.B Rate Application

The following diagram depicts a typical Service configuration:

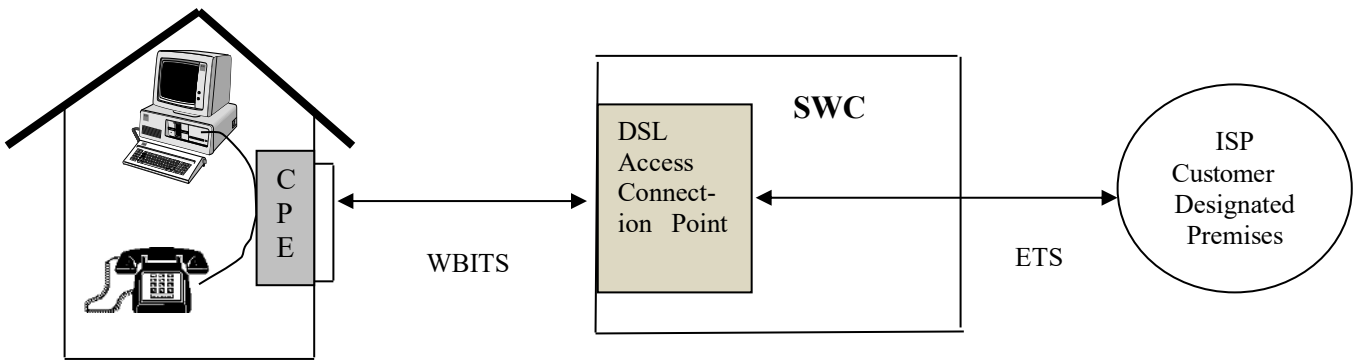

WBITS
End User
Subscriber
Designated
Premises

CPE = Customer Premises Equipment

ETS = Ethernet Transport Service

SWC = Serving Wire Center

WBITS = Wireline Broadband Internet Transport Service

3.4.C Minimum Period

For Service provided outside of a term and volume commitment, the minimum period for which Service is provided to a Wholesale Customer and for which charges are applicable is one month.

3.4.D Moves

A move involves a change in the physical location of one of the following:

- The Point of Termination at the Wholesale Customer's designated premises in the Company's Study Area.
- The End User Subscriber's customer designated premises.

The charges for the move are dependent on whether the move is to a new location within the same building or to a different building.

(1) Moves within the Same Building

When the move is to a new location within the same building, the charge for the move will be an amount equal to one half of the nonrecurring (i.e., installation) charge for the service termination affected. There will be no change in the minimum period requirements.

(2) Moves to a Different Building

Moves to a different building will be treated as a discontinuance and start of Service and all associated nonrecurring charges will apply. New minimum period requirements will be established for the new Services. The Wholesale Customer will also remain responsible for satisfying all outstanding minimum period charges for the discontinued service.

3.4.E Term and Volume Plan (TVP) Rates

(1) Description

The Term and Volume Plan ("TVP") allows Wholesale Customers discounted Monthly Service rates based upon the volume and term commitment.

Term plan of one (1) or three (3) years may be available to all Wholesale Customers at applicable rates set forth in the Rates, Terms and Conditions regardless of when the subscription is made for a TVP arrangement. The Wholesale Customer must designate on the order the type of payment plan selected. The selected term shall apply to all Service access lines ordered by the Wholesale Customer without respect to speed or class. The term commitment is for the aggregate number of Service lines ordered under a volume commitment. If a Wholesale Customer terminates an individual line prior to the running of a term commitment, but the total volume of lines ordered and in service for the Wholesale Customer is above the volume chosen for the term commitment, charges for all remaining lines are not affected. For term commitments, the TVP provides a percentage discount on the Wholesale Customer's total Monthly Recurring Charges aggregate line rates. The TVP percentage discounts do not apply to any additional taxes, fees, or surcharges that may be applicable.

- (2) Rate Application Upon expiration of a TVP period, the Wholesale Customer may choose a new TVP period, convert to month-to-month or terminate Service. The month-to-month rates will be those rates that are in effect at the time of conversion. If the Wholesale Customer fails to make a choice by the end of the TVP period, Services will continue to be billed at the existing term and volume commitment level rates and a new TVP period will begin based on previously effective term and volume commitment. All terms and conditions, including Termination Liabilities will apply to the new TVP period.

Conversion to a month-to-month or a different TVP period will require the Wholesale Customer to submit a change order. Conversion of existing TVP service to a different TVP will be allowed without application of any nonrecurring charges.

- (3) Changes in Length of TVP Period

The Wholesale Customer may elect to convert to a new TVP period subject to the following conditions:

- (a) Credit will not be given toward the new payment period for payments made under the original TVP arrangement;
 - (b) Nonrecurring charges will not be reapplied for existing service(s); and
 - (c) If the new TVP period is shorter in length than the time remaining under the existing TVP, the change to the new TVP period constitutes a discontinuance of the existing TVP Service and termination liability charges apply.
- (4) Rate Changes The Wholesale Customer may terminate the TVP without penalty or liability should the rates increase during the term of the existing TVP, with the exception of rate changes that may occur as a result of any rate increases resulting from FCC prescription or order that either directly or indirectly affects the cost to the Company of providing WBITS.
- (5) TVP Conditions After enrolling in the plan, the Wholesale Customer may delete or add Services rated at the specified term period/threshold level rate at any time during the plan.
- (6) Monthly Minimum Charge for Term and Volume Commitment A Monthly Minimum Charge applies for each term and volume commitment. In the event aggregate charges at the TVP rates applicable for the ordered speeds for the individual Service lines provided by the Company to the Wholesale Customer are less than the Monthly Minimum Charge for the TVP ordered by the Wholesale Customer, the charge by the Company to the Wholesale Customer for the month for Service lines will be the Monthly Minimum Charge in lieu of the aggregate of individual line charges. If the aggregate of individual line charges for a month is higher than the Monthly Minimum Charge, the Wholesale Customer is liable for the charges aggregating higher than the monthly minimum charge.

Notwithstanding billing of a Monthly Minimum Charge for Service lines, the Wholesale Customer remains liable for any charges under these Rates, Terms and Conditions other than line charges that apply for a month such as Nonrecurring Charges. Additionally, the Wholesale Customer's duty to pay for ETS charges under the Company's Interstate Access Services Tariff are not

affected by the monthly minimum charge for TVP elections under these Rates, Terms and Conditions.

- (7) Termination Liability When a TVP Service is discontinued prior to the end of the commitment term, termination liability charges comprise the Monthly Minimum Charge for the applicable term and volume commitment. Monthly Minimum Charge amounts are listed at Section 4.1.C following.

3.4.F Monthly Transfer Limitations

The Company, in its sole discretion, reserves the right to monitor bandwidth usage (i.e., monthly data transfer rate) for each individual Service line and determine when such usage is in excess of the monthly transfer limitation for the Service offering. The monthly period for monitoring is the same month as that for which service is billed by Company to Wholesale Customer for the Service line. In the event Wholesale Customer exceeds the monthly limits established by the Company herein, Wholesale Customer must undertake to limit usage within the monthly period or incur additional fees as stated below.

The monthly transfer limitation for the upstream capacity for an offering is equal to 3,000 KBs for each kb of stated upstream speed for an offering. The monthly transfer limitation for the downstream capacity for an offering is equal to 3,000 KBs for each kb of stated downstream speed for the offering. For example, an offering with 1 Mbps upstream speed and 10 Mbps downstream speed would have a monthly transfer limitation for upstream of 3,000 KBs (or 3 GBs) and a monthly transfer limitation for downstream of 30,000 KB (or 30 GBs).

In the event Company monitoring of Bandwidth usage indicates imposition of a limitation within the monthly limitation of 3,000 KB per 1 kb, Wholesale Customer may order additional monthly transfer capacity for an individual line at a charge of ten cents (\$0.10) per month for each additional 1,000 KB of upstream data transfer and ten cents (\$0.10) per month for each additional 1,000 KB of downstream data transfer. The monthly transfer limitations applicable to the individual Service line for which additional transfer capacity is ordered will be increased from 3,000 KB per kb reflective of the individual monthly transfer capacity ordered for either upstream or downstream.

Section 4: Rates and Charges

4.1.A Monthly Recurring and Nonrecurring Line Charges

Service Provided over Residential and Business Lines – No Term Commitment

Voice-Data or Data-Only Option	Term Commitment	Speed (Mbps) – Up To		Monthly Recurring Charges			Non-recurring Charge
		Down-stream	Up-stream	Month-to-Month			
Voice-Data	None	10 Mbps	10 Mbps	\$42.00			\$185.00